

Model: Day Cab Air Conditioning System



2390 Blackhawk Road • Rockford, IL 61125
USA • 815-874-7821



Technical Specifications

- | | |
|--------------------------------------|-----------------------------------|
| | Cooling |
| • Performance | 7,200 Btuh
2.11 kW |
| • Air Flow | 180 cfm
323 m ³ /hr |
| • Current Draw | 25-55 amps @ 12vdc
636 Watts |
| • System requires refrigerant charge | |

Features

- Split system: condenser unit outside, evaporator unit inside cab
- 3 fan speeds
- Virtually maintenance free
- Quiet operation
- Easy to clean interior filter
- Optional voltages available on request

Construction

- Shell constructed with durable steel
- Electrified unit, runs on auxiliary AGM / deep cycle batteries (minimum 12v required)
- R134a refrigerant

Weights and Dimensions

	Interior Unit	Exterior Unit
• Weight	52 lbs 23.6 kg	25 lbs 11.3 kg
• Length	10.9 in 276.4 mm	18.9 in 480.8 mm
• Depth	10.9 in 276.4 mm	6.6 in 167.8 mm
• Height	27.3 in 692.3 mm	13.4 in 339.1 mm

Warranty

- 1 year limited warranty parts and labor

www.nitesystem.com

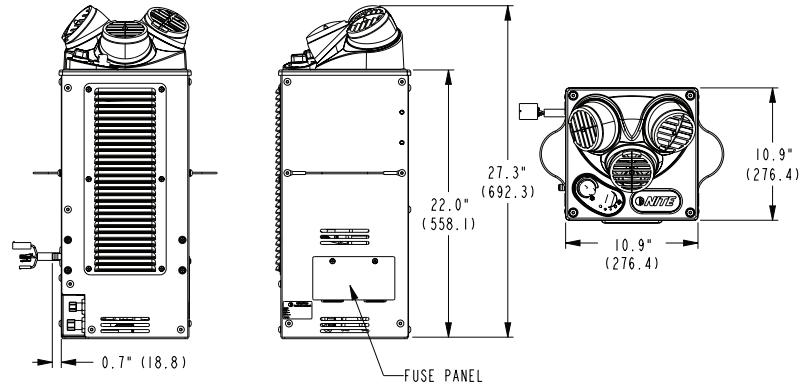

Interior Evaporator Unit

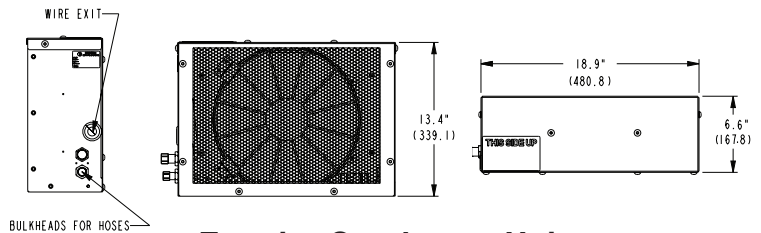

Exterior Condenser Unit

Distributed by